

ORDER REFERENCE

PROJECT: UC601 HYDRAULIC DRIVE
TYPICAL LAYOUT

PLEASE REFER TO PAGE 7
OF THE PLANNING GUIDE FOR
ADDITIONAL SIZING OPTIONS

HYDRAULIC DRIVE
OFFERS A MAXIMUM OF:
6 STOPS
50'-0" OF TRAVEL
15 SQ. FT. CAB SIZE

SPECIFICATIONS

DRIVE: UC601 HYDRAULIC DRIVE

CAPACITY: 1000#

MANUFACTURED TO MEET:
ASME A17.1 – 2016

LANDINGS: 3

IT IS THE RESPONSIBILITY OF THE INSTALLER OF THE UNIT
TO SATISFY ASME, NEC, STATE, AND LOCAL BUILDING CODES

CODE(S): 1 (INCLINATOR LAYOUT DESIGN)

SPEED: AT 36 F.P.M. ±4

SUSPENSION (2) STEEL WIRE ROPES 12,100#

MEANS: BREAKING STRENGTH $\phi 3/8$ – 8 x 19 IWRC

CAR CONSTRUCTION: 3/4" HARDWOOD VENEER

NOTE: ALL MANUFACTURER SUPPLIED CAR AND EQUIPMENT OPTIONS ARE
NOTED ON THE CONFIRMING ORDER SHEET.

DISCLAIMER: ONCE DRAWINGS HAVE BEEN APPROVED,
SIGNED AND WITHIN 5 DAYS OF PRODUCTION, THE
CUSTOMER WILL BEAR ALL RESPONSIBILITY AND LIABILITY
OF FINISHED UNIT.

DWG VIEW

COVER SHEET

PART NUMBER

80205325

REV. DATE

11/06/19



DRAWING TITLE

TYPICAL UC601 HYDRAULIC

DRAWING NO.

TYP-HYD-062

PAGE:
1/5

DRAWN BY:
S THOMAS

DWG. DATE
3/2017

JOB OR APP.#
-

DEALER P.O.#
-

DWG. SCALE
1:24

REV. LEVEL(1-3)
A

NOT TO BE USED FOR CONSTRUCTION
TYPICAL DRAWING

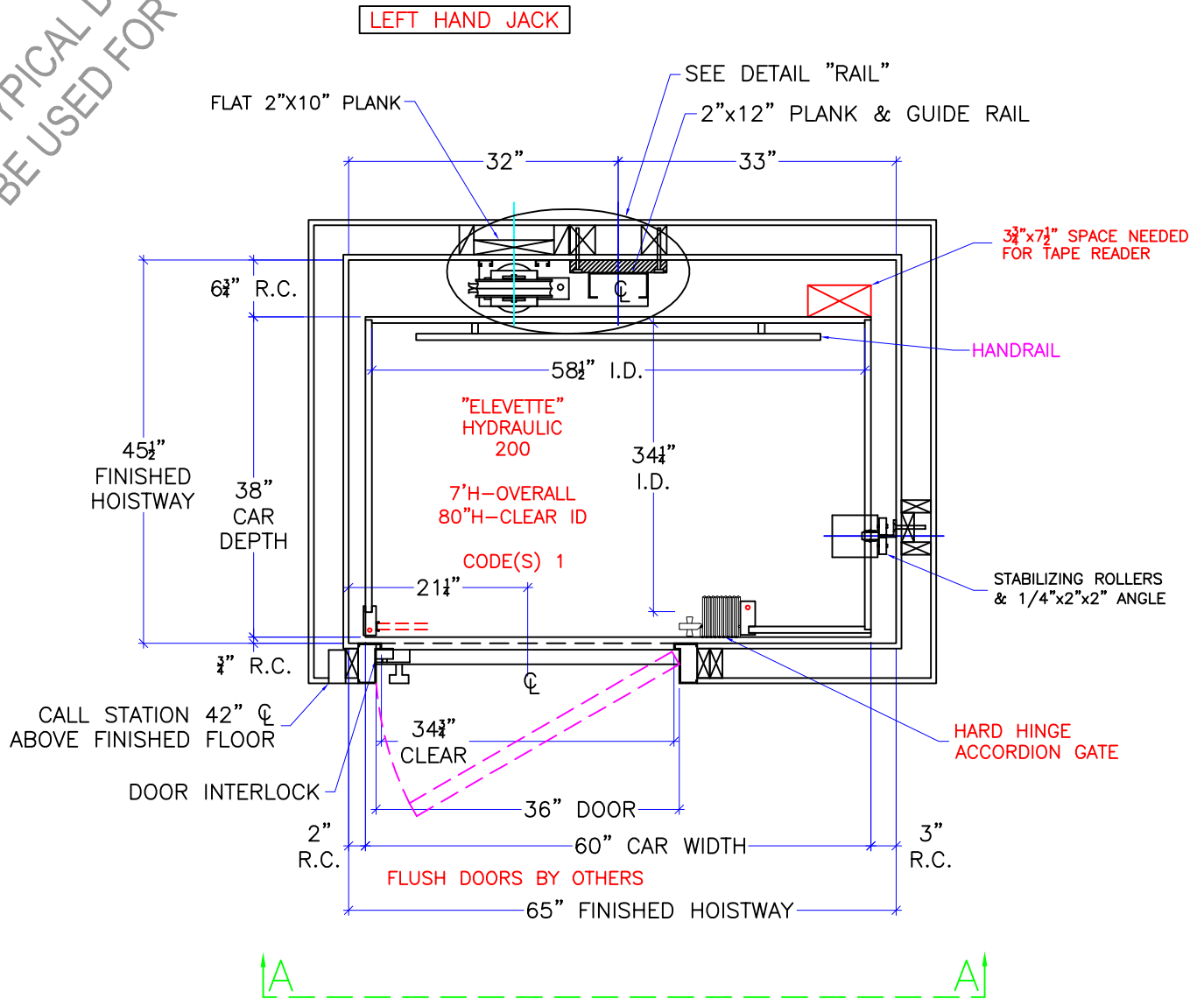

NOTE:
ALL HOISTWAY CONSTRUCTION MUST COMPLY WITH NATIONAL, STATE,
AND LOCAL CODES. HOISTWAY MUST BE PLUMB AND STRAIGHT
FROM TOP TO BOTTOM WITH NO PROJECTIONS INTO THE HOISTWAY.

DWG VIEW		HOISTWAY LAYOUT		PART NUMBER		REV. DATE	
INCLINATOR COMPANY OF AMERICA HARRISBURG, PA		DRAWING TITLE		80205325		11/06/19	
TYPICAL UC601 HYDRAULIC		DRAWING NO.		TYP-HYD-062		-	
PAGE:	DRAWN BY:	DWG. DATE	JOB OR APP.#	DEALER P.O.#	DWG. SCALE	REV. LEVEL(1-3)	
2/5	S THOMAS	3/2017	-	-	1:24	A	

NOT TO BE USED FOR CONSTRUCTION
TYPICAL DRAWING

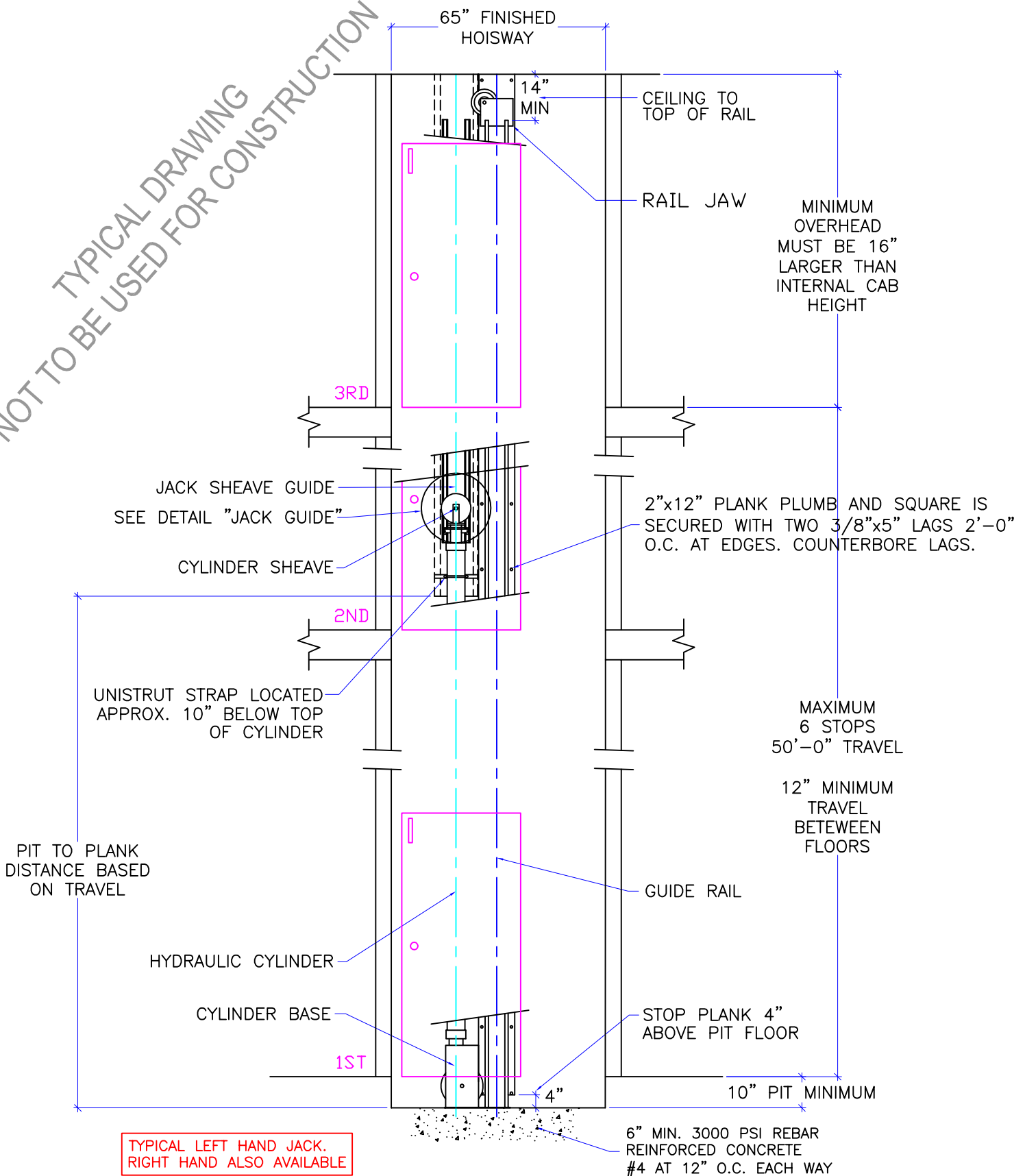

VIEW A-A

DWG VIEW		SECTION A-A		PART NUMBER		REV. DATE	
				80205325		11/06/19	
INCLINATOR COMPANY OF AMERICA HARRISBURG, PA		DRAWING TITLE		DRAWING NO.		-	
		TYPICAL UC601 HYDRAULIC		TYP-HYD-062		-	
PAGE:	DRAWN BY:	DWG. DATE	JOB OR APP.#	DEALER P.O.#	DWG. SCALE	REV. LEVEL(1-3)	
3/5	S THOMAS	3/2017	-	-	1:24	A	

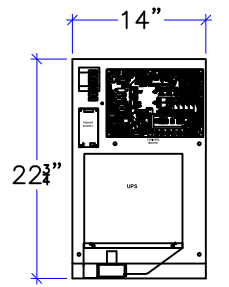
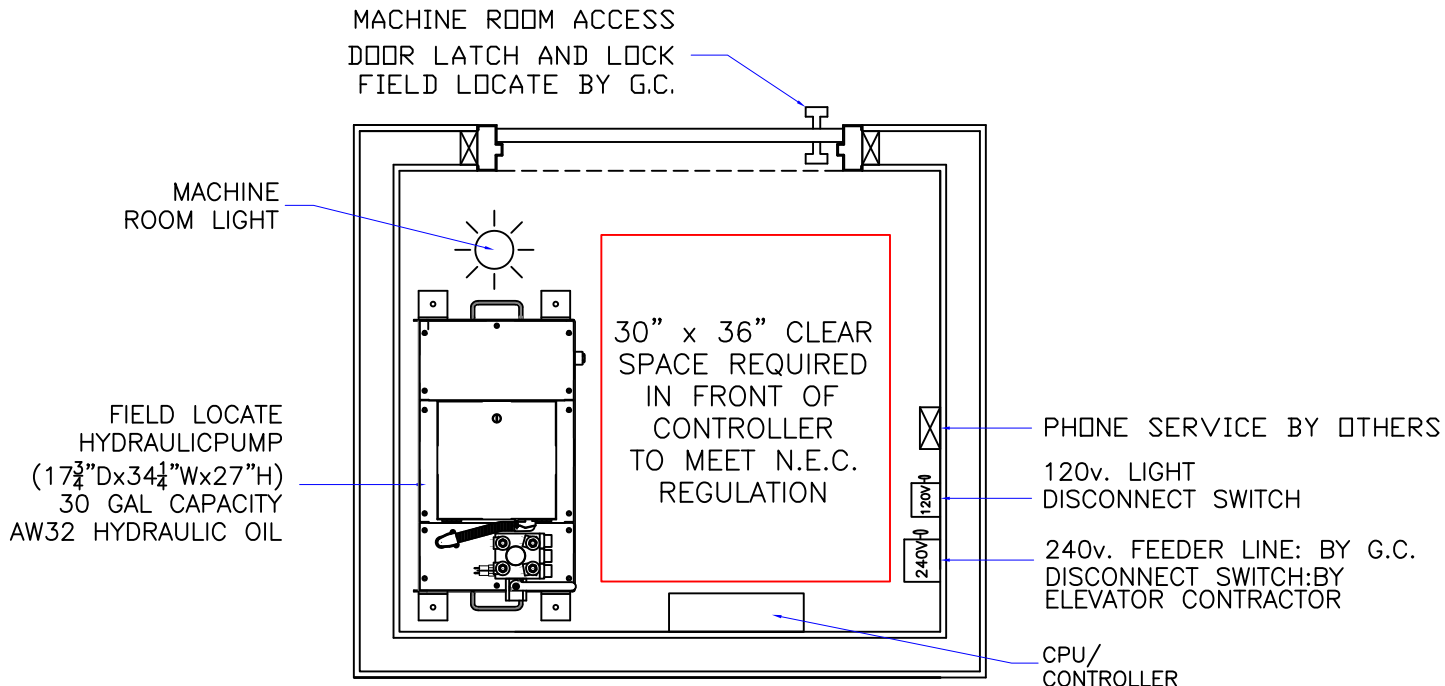

CPU ENCLOSURE
(14"W x 22 3/4"H x 4"D)

CONTROLLER SPACE:

- 1: THE CPU AND PUMP UNIT SHOULD BE LOCATED IN THE SAME LOCATION. THE RECOMMENDED WIRING DISTANCE FROM THE CPU TO THE PUMP UNIT TO BE 10'. LONGER MOTOR CABLES UP TO 40' ARE AVAILABLE. CONSULT WITH INCLINATOR WHEN ORDERING.
- 2: CONTROLLER SHOULD BE MOUNTED IN A TEMPERATURE CONTROLLED ENVIRONMENT BETWEEN 40°F TO 120°F (4°C - 49°C).
- 3: CPU AND PUMP UNIT SHOULD NOT BE EXPOSED TO OUTDOOR ELEMENTS.
- 4: N.E.C. REGULATIONS REQUIRE A MINIMUM OF 30" WIDE x 36" DEEP x 6'-6" HIGH CLEAR UNOBSTRUCTED SPACE IN FRONT OF CONTROLLER.
5. MACHINE ROOM TO HAVE NATURAL/MECHANICAL VENTILATION IF REQUIRED BY STATE OR LOCAL CODES.
6. MACHINE ROOM LAYOUT MUST COMPLY WITH LOCAL, STATE, AND NATIONAL CODES.

NOTICE TO ELECTRICAL CONTRACTOR:

- ALL ELECTRICAL WIRING MUST BE DONE BY A JOURNEYMAN MECHANIC AND MUST MEET ALL NATIONAL, STATE, AND LOCAL CODES.
- BRING (2) #10 W/GND FROM RESIDENCE INCOMING POWER PANEL 30AMP BREAKER (240V, & GROUND) TO THE CONTROLLER SPACE.
- BRING (2) #12 W/GND FROM RESIDENCE INCOMING POWER PANEL 20AMP GFI BREAKER (120V, NEUTRAL, GROUND) TO THE MACHINE ROOM.
- REQUIRED LOW VOLTAGE WIRING IS SUPPLIED BY MANUFACTURER. ALL EXTENSIONS ADDITIONS, ETC. SHALL BE DONE WITH THE SAME SIZE AND TYPE OF WIRE AS ORIGINALLY SUPPLIED BY THE MANUFACTURER.
- A TELEPHONE LINE SHALL BE SUPPLIED TO THE CONTROLLER SPACE AND SHALL BE CONNECTED TO A 24 HOUR CENTRAL EXCHANGE.
- ALL MEANS FOR ACCESS TO EQUIPMENT SHALL BE PROVIDED WITH A LOCK. ALL SHAFT DOORS MUST BE INTERLOCKED.

DWG VIEW		PART NUMBER		REV. DATE		
CONTROLLER SPACE REQUIREMENTS		80205325		-		
DRAWING TITLE		DRAWING NO.		-		
TYPICAL UC601 HYDRAULIC		TYP-HYDRO		-		
PAGE:	DRAWN BY:	DWG. DATE	JOB OR APP.#	DEALER P.O.#	DWG. SCALE	REV. LEVEL(1-3)
4/5	S THOMAS	3/2017	-	-	1:24	-



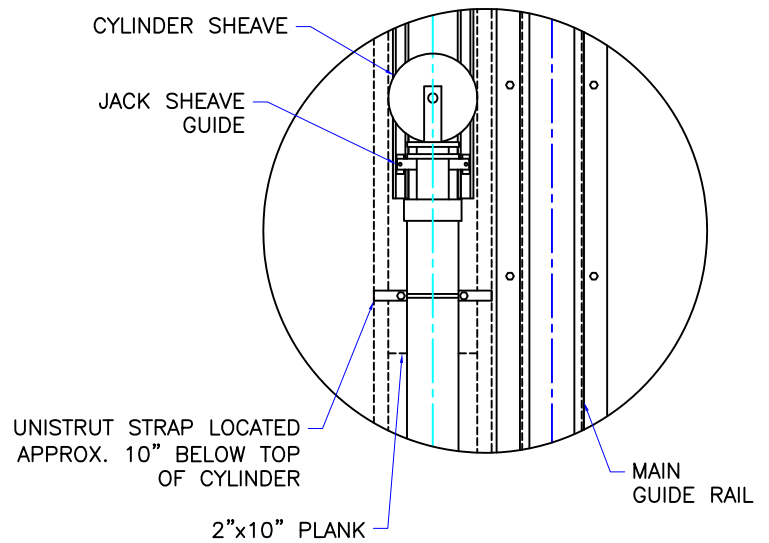
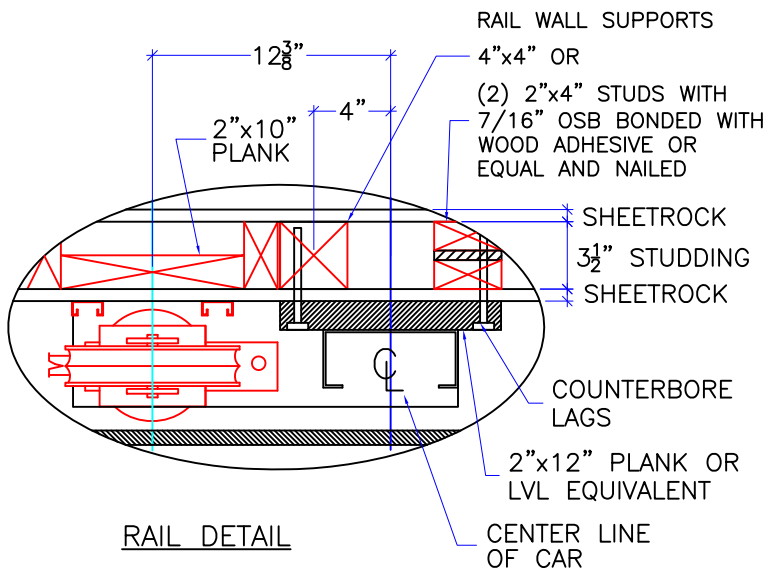

NOTE:
 JACK SHEAVE GUIDE MUST BE INSTALLED PARALLEL TO MAIN GUIDE RAIL, PLUMB w/ JACK ON INSTALLATION. UNISTRUT TO BE FASTENED TO THE SUPPORT PLANK EVERY 3'-0".

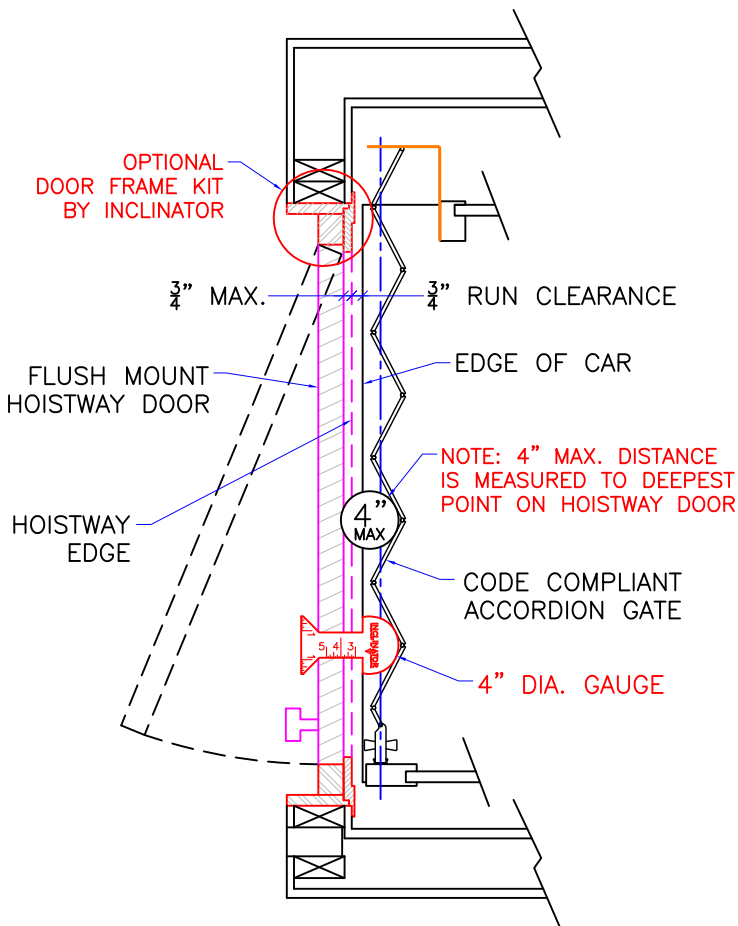

REF: ASME 17.1-2016 5.3.1.4.2, 5.3.1.7.2, & 5.3.1.8.3

JACK GUIDE DETAIL

1. VERTICAL LOAD FORCES
 STATIC = 2,230 LBS.
 IMPACT = 4,460 LBS.
2. RAIL FASTENING TO 2"x12" PLANK:
 #14 x 1 3/4" TYPE A S.M.S. RAIL IS PRE-DRILLED AT FACTORY.
3. BOLT FASTENING OF CAR TO TROLLEY:
 1/2" - 13 x 4" SOCKET HD CAP SCREWS
4. JACK SPECIFICATIONS
 - A. SINGLE PC JACKS
 PISTON DIA. 2 5/16"
 WALL THICK. 11/32"
 - B. SPLICED JACKS
 PISTON DIA. 2 13/16"
 WALL THICK. 9/32"
 - C. ALL CYLINDERS
 OUTSIDE DIA. 4"
 WALL THICK. 3/16"
 - D. MAX WORKING PRESS. 1000 PSI
5. ALL SHEAVE DIA. 8 5/16"

TECHNICAL DATA

DWG VIEW		PART NUMBER		REV. DATE		
DETAILS, DATA, CODES		80205325		-		
DRAWING TITLE		DRAWING NO.		-		
TYPICAL UC601 HYDRAULIC		TYP-HYDRO		-		
PAGE:	DRAWN BY:	DWG. DATE	JOB OR APP.#	DEALER P.O.#	DWG. SCALE	REV. LEVEL(1-3)
5/5	S THOMAS	3/2017	-	-	1:24	-



SECTION					X - X AXIS				Y - Y AXIS		
MEMBER	WT.	HT.	W	A	I	S	r	Z	I	S	r
					in. ⁴	in. ³	in.	in.	in. ⁴	in. ³	in.
SINGLE CHANNEL											
A-1400	1.40	1.625	1.625	.401	.134	.146	.577	.707	.184	.226	.677

LOAD RATINGS FOR 3/8-16 STRUT NUTS USED IN SUPERSTRUT CHANNELS		
CHANNEL NO.	SLIP RESISTANCE LBS.	PULL OUT STRENGTH LBS.
A - 1400	1000	2000

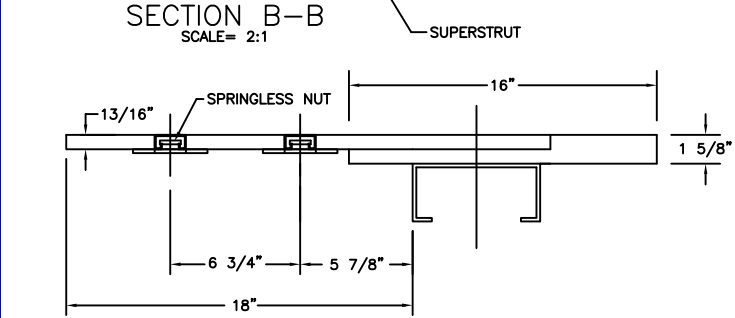
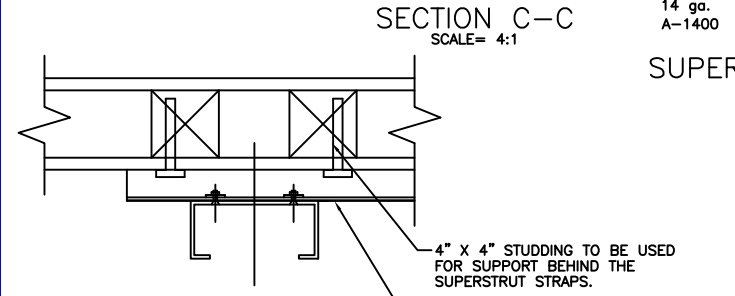
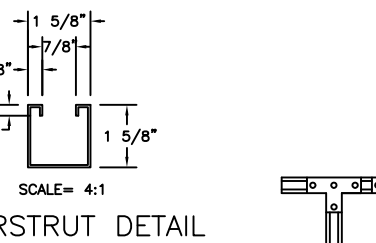
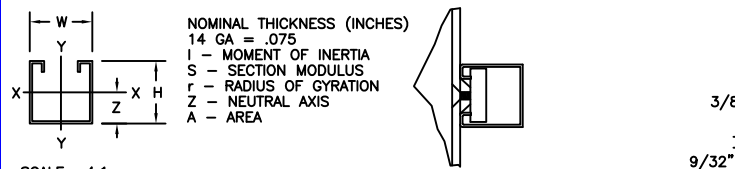

MOUNTING TO CONCRETE

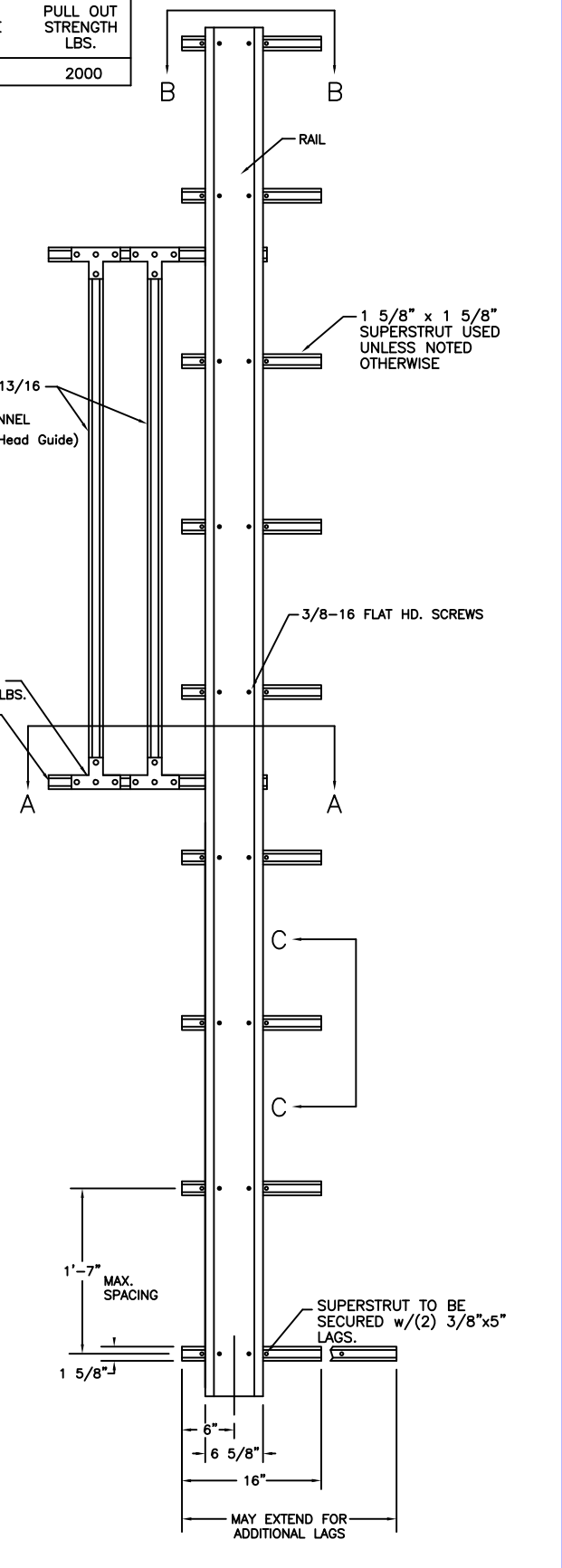
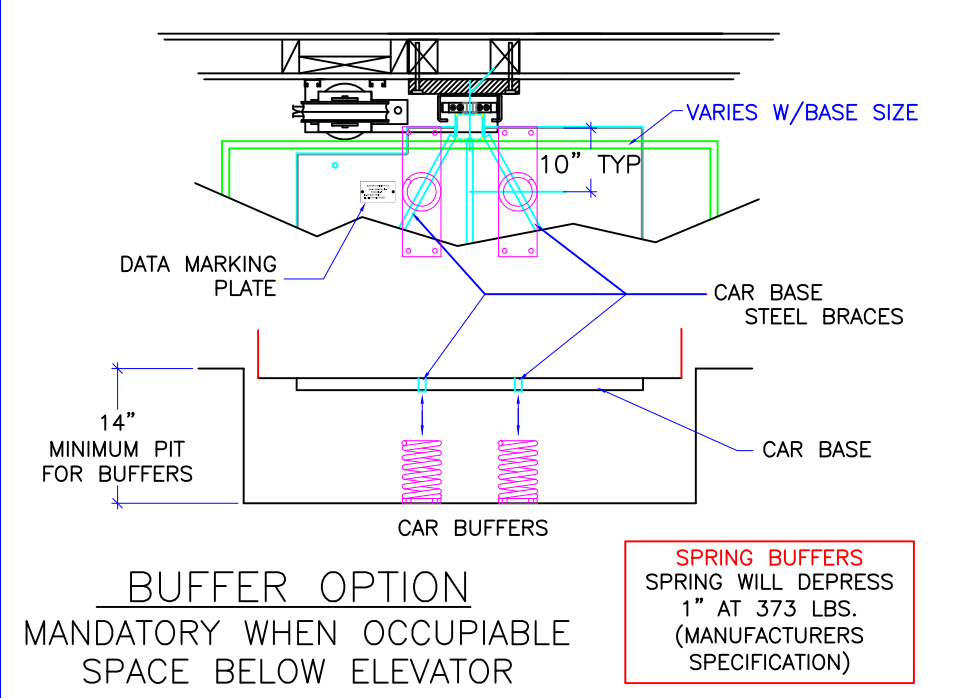

DWG VIEW				PART NUMBER		REV. DATE	
OPTIONS				80205325		-	
DRAWING TITLE				DRAWING NO.		-	
TYPICAL UC601 HYDRAULIC				TYP-HYDRO		-	
PAGE:	DRAWN BY:	DWG. DATE	JOB OR APP.#	DEALER P.O.#	DWG. SCALE	REV. LEVEL(1-3)	
AUX 1	S THOMAS	3/2017	-	-	1:24	-	

INCLINATOR
COMPANY OF AMERICA
HARRISBURG, PA

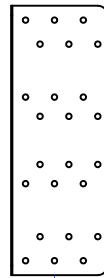
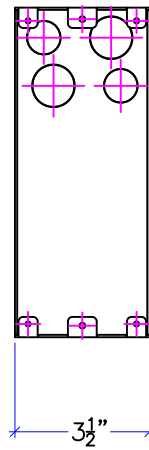
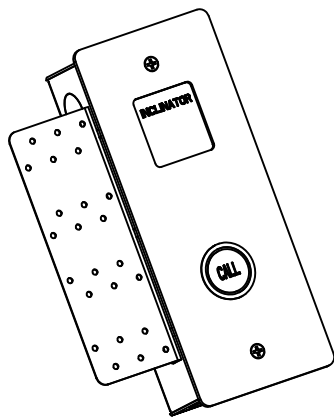

NAIL PLATE
MOUNTING
BRACKET
PROVIDED BY
INCLINATOR

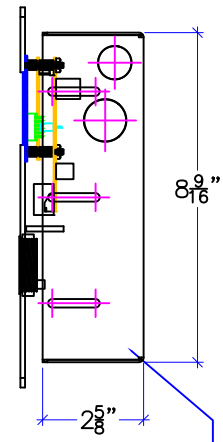

HALL CALL MOUNTING
BOX PROVIDED BY
INCLINATOR

FLUSH MOUNT HALL CALL STATION

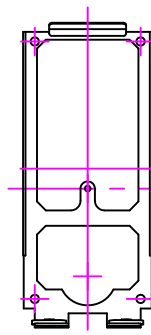
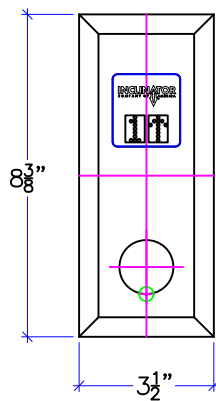
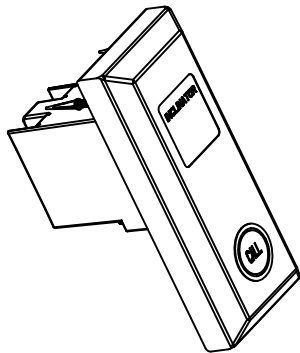

WALL BRACKET
PROVIDED BY
INCLINATOR

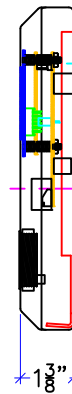

SINGLE GANG
MOUNT ELECTRICAL
BOX BY OTHERS

THIS HOLE USED
TO LOCATE BRACKET
OVER GANG BOX

RAISED MOUNT HALL CALL STATION

DWG VIEW

CALL STATIONS

PART NUMBER

80205325

REV. DATE

DRAWING TITLE

DRAWING NO.

—

TYPICAL UC601 HYDRAULIC

TYP-HYDRO

—

PAGE:

DRAWN BY:

DWG. DATE

JOB OR APP.#

DEALER P.O.#

DWG. SCALE

REV. LEVEL(1-3)

AUX 2

S THOMAS

3/2017

—

—

1:24

—



DOOR FRAME DETAIL
 STANDARD 2x4 CONSTRUCTION WITH
 1/2" DRYWALL (INSIDE & OUTSIDE OF HOISTWAY)

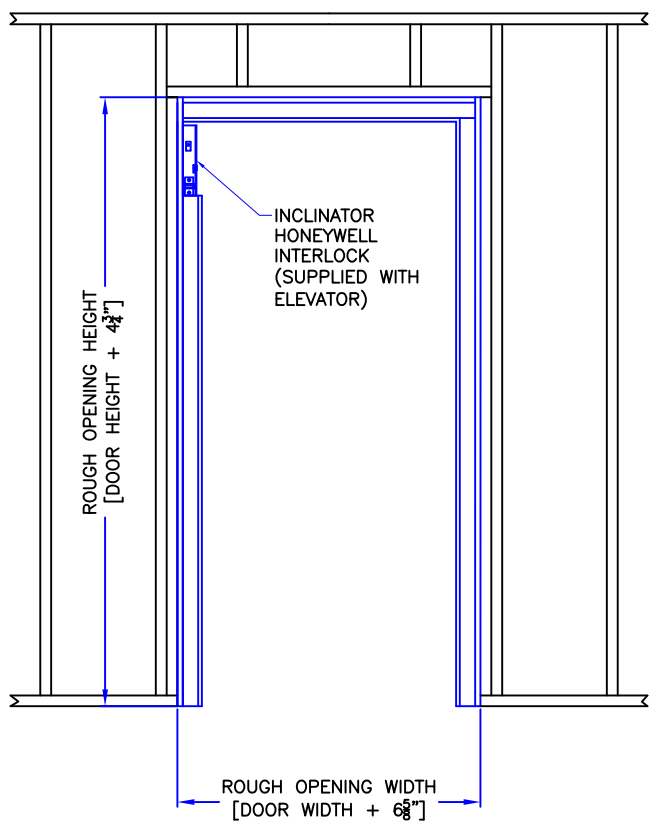

HALLWAY VIEW



HOISTWAY VIEW

DWG VIEW		PART NUMBER		REV. DATE		
DOOR FRAME KITS		80205325		-		
DRAWING TITLE		DRAWING NO.		-		
TYPICAL UC601 HYDRAULIC		21211403		-		
PAGE:	DRAWN BY:	DWG. DATE	JOB OR APP.#	DEALER P.O.#	DWG. SCALE	REV. LEVEL(1-3)
AUX 3	S THOMAS	3/2017	-	-	1:24	-

